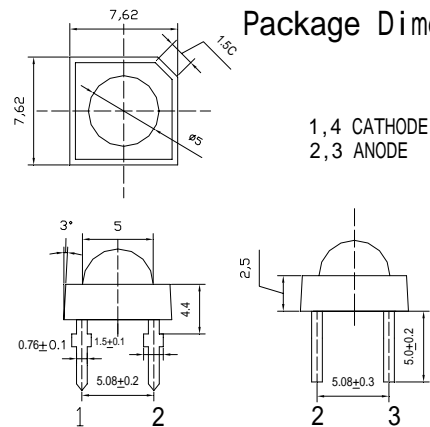

**■Features**

- Super Flux Output
- Water Clear Type
- Low Thermal resistance
- Design For High Current Operation.
- RoHS compliant

**■Applications**

- Automotive Dashboard Lighting
- Traffic signal lamp

**■Outline Dimension**

**■Absolute Maximum Rating**

(Ta=25 )

Item	Symbol	Value	Unit
DC Forward Current	$I_F$	30	mA
Pulse Forward Current*	$I_{FP}$	100	mA
Reverse Voltage	$V_R$	5	V
Power Dissipation	$P_D$	120	mW
Operating Temperature	$T_{opr}$	-30 ~ +85	
Storage Temperature	$T_{stg}$	-30 ~ +100	
Lead Soldering Temperature	$T_{sol}$	260 /3sec	-

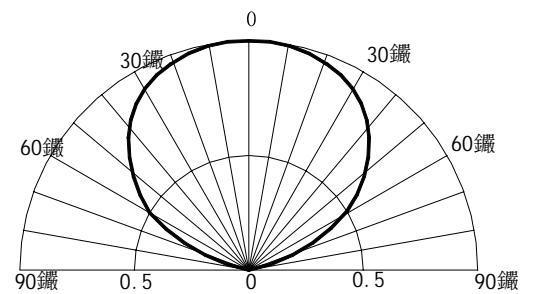
\*Pulse width Max.10ms Duty ratio max 1/10

**■Directivity**

**■Electrical -Optical Characteristics**

(Ta=25 )

Item	Symbol	Condition	Min.	Typ.	Max.	Unit
DC Forward Voltage	$V_F$	$I_F=20mA$	2.8	3.4	4.0	V
DC Reverse Current	$I_R$	$V_R=5V$	-	-	10	$\mu A$
Dom. Wavelength	$\lambda_D$	$I_F=20mA$	520	525	530	nm
Luminous Intensity	$I_v$	$I_F=20mA$	2180	2500	3000	mcd
50% Power Angle	$2\theta_{1/2}$	$I_F=20mA$	-	120	-	deg